

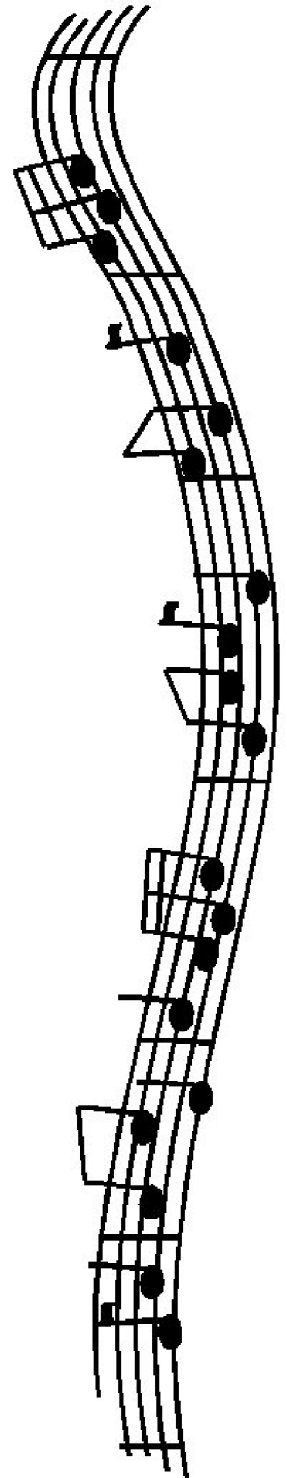

Grifftabellen für Saxophon

- bearbeitet von Udo Daurer -

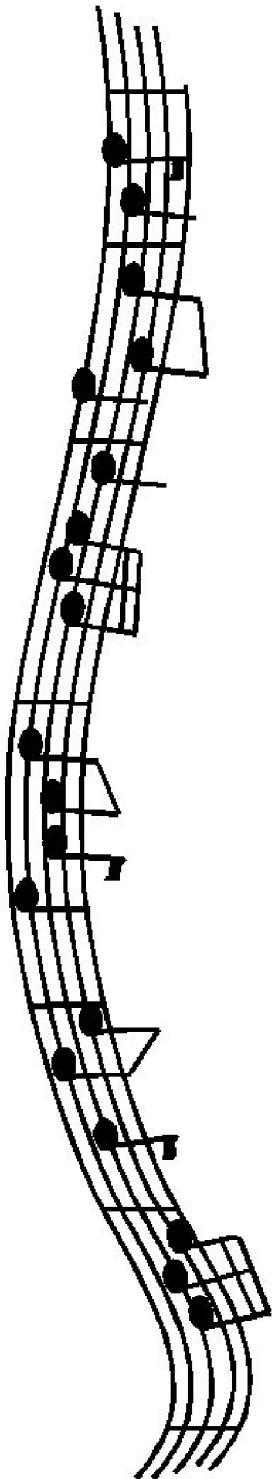

Oktav-Klappe

F	8
Es	f
D	H/B
Bb	A
	G
gis	F
cis h	E
Bb	D
	fis
	fa/T
	Es
	C

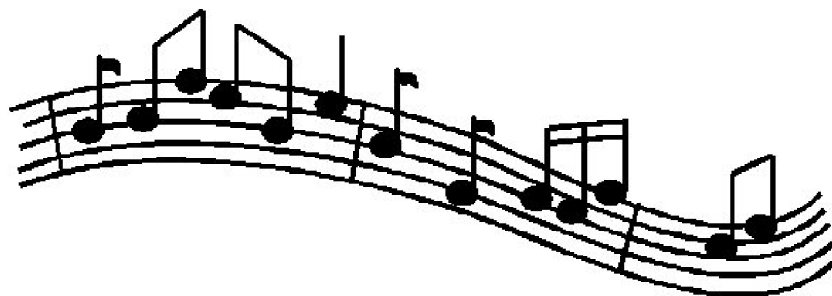

Grifftabelle für Saxophon

Bb	B	C	Cis	D	Es	E	F

Fis	II	III Tr.	G	As	A	Bb _s	D

1	2	3	B	C	II Tr.	III	Cis

II	D	Es	E	F	Fis	II	III Tr.

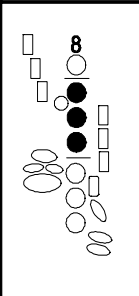
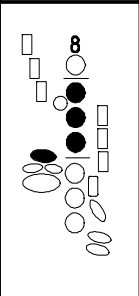
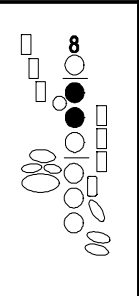
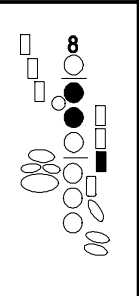
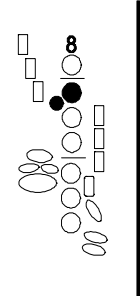
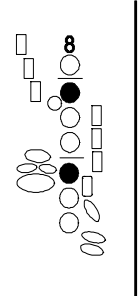
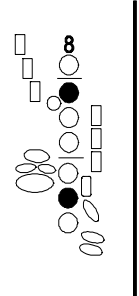
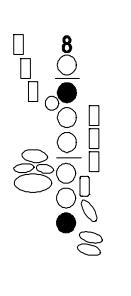
G	As	A	Bb	D	1	2	3
							

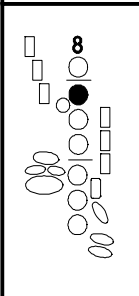
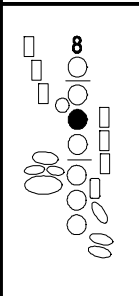
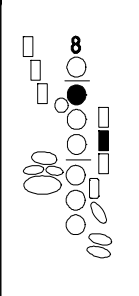
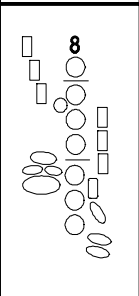
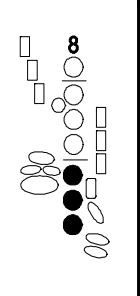
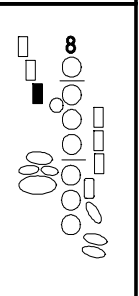
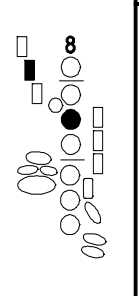
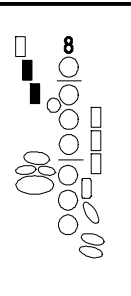
B	C	II Tr.	Cis	II	D	II	Es
							

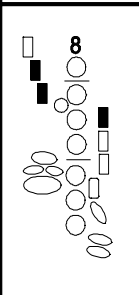
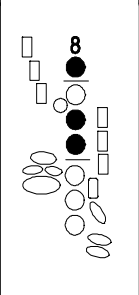
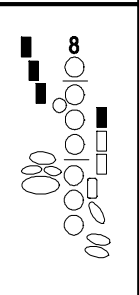
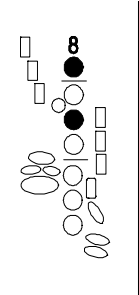
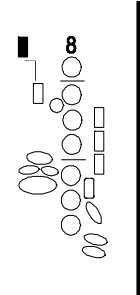
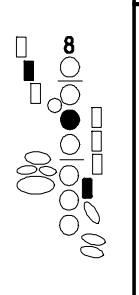
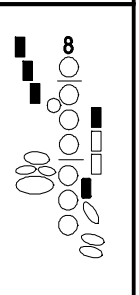
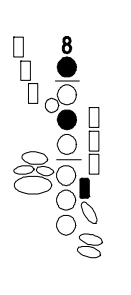
E	II o	F	II o	III	IV	Fis	II o
							

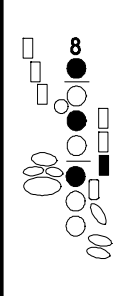
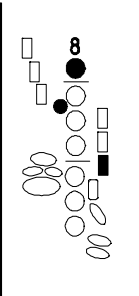
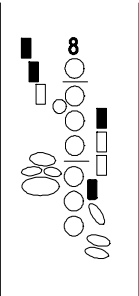
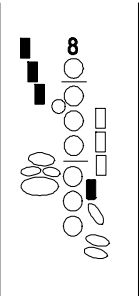
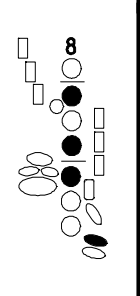
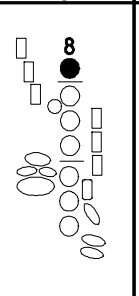
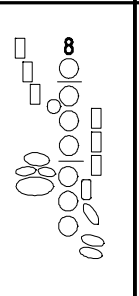
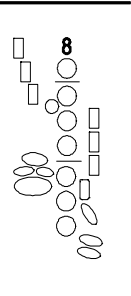
III o	IV o	V Tr.	VI	VII	G o		
							

Triller-Tabelle

Der Triller besteht aus HAUPTTON und TRILLERTON. In der Schreibweise wird der Hauptton angegeben. Der Trillerton ist, wenn nicht besonders gekennzeichnet, der nächst höhere in der vorgeschriebenen Tonart. Der Abschluß des Trillers wird wieder wie angegeben gegriffen.

Ausführung des TRILLERS:

Der Hauptton wird angeblasen (der Griff bleibt, soweit als erforderlich, liegen), die für den Triller benötigte Klappe wird rasch betätigt.

Schreibweise:

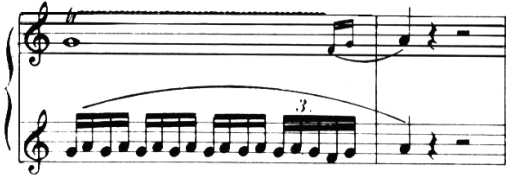

Ausführung:

Die nachstehende Trillertabelle umfaßt die auf dem Saxophon möglichen Triller.

<p>Hauptton C: Trillerton D:</p>		<p>Hauptton C: Trillerton Des:</p>	
<p>Hauptton Cis: Trillerton D:</p>		<p>Hauptton D: Cis liegen lassen Trillerton E:</p>	
<p>Hauptton Dis: Trillerton E:</p>		<p>Hauptton Es: Trillerton F:</p>	
<p>Hauptton E: Trillerton Fis:</p>		<p>Hauptton E: Trillerton Fis:</p>	
<p>Hauptton F: Trillerton Ges:</p>		<p>Hauptton F: Trillerton G:</p>	
<p>Hauptton Fis: Trillerton G:</p>		<p>Hauptton Ges: Trillerton As:</p>	
<p>Hauptton G: Trillerton As:</p>		<p>Hauptton G: Trillerton A:</p>	
<p>Hauptton Gis: Trillerton As:</p>		<p>Hauptton As: Trillerton B:</p>	

Hauptton Gis:
Trillerton A:

Hauptton A:
Trillerton H:

Hauptton A:
Trillerton B:

Hauptton B:
Trillerton C:

Hauptton Ais:
Trillerton H:

Hauptton H:
Trillerton Cis:

Hauptton H:
Trillerton C:

Hauptton C:
Trillerton D:

Hauptton C:
Trillerton Des:

Hauptton Des:
Trillerton Es:

Hauptton Cis:
Trillerton D:

Hauptton D:
Trillerton E:

Hauptton D:
Trillerton Es:

Hauptton Es:
Trillerton F:

Hauptton Dis:
Trillerton E:

Hauptton E:
Trillerton F:

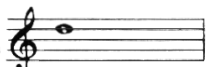
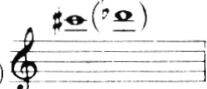
Die Triller, welche zwischen dem D  und dem Cis (Des)  liegen, werden wie die vorher beschriebenen, jedoch zusätzlich mit der Oktave-Klappe ausgeführt.

Steht über dem Triller ein Versetzungszeichen, so wird der Trillerton um einen halben Ton erhöht, bzw. erniedrigt, oder aufgelöst, z. B.:

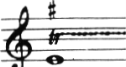
Es wird nicht mit F, sondern mit Fis getrillert. 

Es wird nicht mit H, sondern mit B getrillert. 

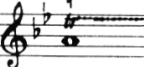
Es wird nicht mit B, sondern mit H getrillert. 

High-Notes Tenor-Sax

Fis ○	II	III ○	IV ○	G	II	III G-F#	IV

As	II Yan.	III	A	II	Bb	II	III



IV	V	B	II	III	IV	C	II



III Yan.	IV	Cis	II	III	D	II C-D	III

Es	II	E	II	F	II	III

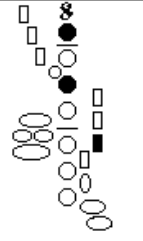
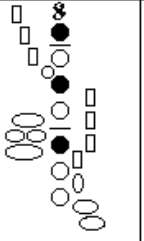
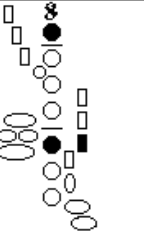
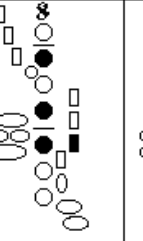
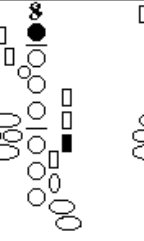
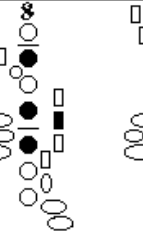
High-Notes

Alto-Sax

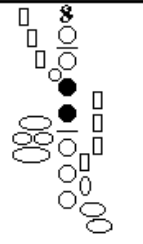
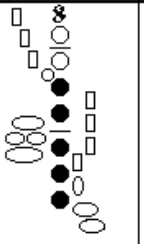
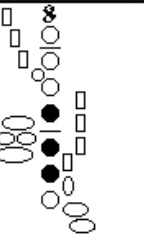
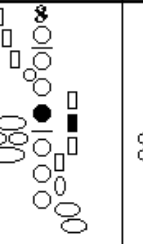
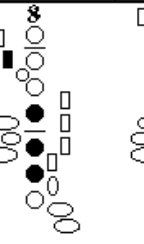
Fis	II	G	II	As	II	III
						

A	II	Bb	II	B	II	III
						

C	II	III	Cis	D	Es	E	F
